

Research Article

Safety, Efficacy and Patient Tolerance of the New 360° Cryoadipolysis Device for Multiple-Area Fat Removal

 Gregorio Viera Mármol,  Carmen Cano Ochoa,  Maria de los Llanos Pérez,  Jorge Villena Garcia,  Reyna Vargas Lamas,  Mar Altaba Rosas,  Núria Adell Gómez,  Jackie Law

Department of Clinical and Scientific, Cocoon Medical S.L.U., Barcelona, Spain

Abstract

Objectives: Cryoadipolysis is a non-invasive technique for complete body remodeling. It is a permanent fat reduction option for patients with localized unwanted fat. Due to the unique advantages of the technology, it provides multiple benefits compared to other options. The primary objective of this study is to compare the new Cooltech Define 360° applicators compared with the previous generation of Cooltech applicators. The secondary objective of this study is to evaluate the efficacy and safety of Cooltech Define.

Methods: This study is divided into 2 parts. The first part compares the results achieved by the new 360° Cooltech Define applicators that reach -10°C versus the Cooltech applicators that reach -8°C. This prospective study involved 10 subjects and 13 sessions. All subjects received a 70-minute procedure with both applicators and at the maximum suction level. The second part of the study evaluates the efficacy of Cooltech Define on 23 subjects, A simultaneous multi-procedure was performed on up to 4 areas with different homogenous cooling applicators. All subjects received one session per area. Clinical data was well recorded with assessments completed before and after the procedure under evaluation using callipers, perimeter measurements and iconography. All potential side effects were also well documented.

Results: In the first part of the study, the comparison shows that Cooltech Define provides greater comfort during the procedure due to the design of the new applicator cup which allows the tissue to sit in the applicator without pulling on it strongly. The lower temperature induces hypoesthesia in the tissue more quickly. The sensation of pain from post-procedure massage and common side effects were higher than with Cooltech, especially for the evaluation of erythema and paresthesia or dysesthesia due to the more intense cooling. All subjects were able to return to daily activity without any notable complaints. All side effects were self-limiting and resolved completely without long-term sequelae. In the second part of the study, the average skin fold change was -7.80 mm (± 3.46 mm) while the average circumference change was -32.3 mm (± 18.6 mm), with the highest results achieved being 20 mm and 80 mm respectively on subjects receiving up to 4 simultaneous treatments. The results were shown in all treated areas for all applicators used on both genders.

Conclusion: Both the Cooltech and Cooltech Define procedures based on cryoadipolysis technology provide safe and highly tolerated treatments for the reduction of localized fat, with minimal and reversible side effects. The new Cooltech Define device has 4 applicators that can provide up to 4 simultaneous treatments in one session, it uses lower temperatures and, thanks to the new applicator design, provides faster and homogenous cooling. It achieves superior results for localized unwanted fat reduction while also providing greater patient comfort. The results show the average skin fold change to be -7.80 mm (± 3.46 mm) with a maximum change of 20 mm (50% reduction), and the average circumference change was -32.3 mm (± 18.6 mm) with the highest result achieved in this study being 80 mm.

Keywords: cryoadipolysis; non-invasive fat removal; lipolysis; apoptosis; adipocyte; non-invasive body contouring; multiple treatments; 360° applicators; 4 applicators

Cite This Article: Viera Mármol G, Cano Ochoa C, de los Llanos Pérez M, Villena Garcia J, Vargas Lamas R, Altaba Rosas M. Safety, Efficacy and Patient Tolerance of the New 360° Cryoadipolysis Device for Multiple-Area Fat Removal. EJMI 2019.

Address for correspondence: Gregorio Viera Mármol, MD. Cocoon Medical - R&D Department Passatge de Masoliver, 24 Barcelona Barcelona 08005 Spain

Phone: +34934588566 **E-mail:** gregoriioviera@cocoonmedical.com

©Copyright 2019 by Eurasian Journal of Medicine and Investigation - Available online at www.ejmi.org

OPEN ACCESS This work is licensed under a Creative Commons Attribution-NonCommercial 4.0 International License.



Cryoadipolysis is a non-invasive technique for complete body remodeling that provides a permanent fat reduction option for patients. Due to the unique advantages of this technology, it provides multiple benefits compared to other cryoadipolysis devices on the market.^[1-3] The key objective of the company is to offer safer and more effective devices that will satisfy the most demanding customers.

In 2018, a scientific study conducted at Cocoon Medical Laboratories in Barcelona (Spain) compared the cooling dynamics of new cryoadipolysis applicators (Cooltech Define) with the cryoadipolysis device that was on the market (Cooltech®). Comparative analyses were carried out with 3D designs imported from the Solid Works® software directly into the COMSOL Multiphysics® simulation software.^[6] The design parameters were: (1) cooling surface, (2) total cavity volume, (3) cavity depth and (4) surface of the applicator head. To optimize the design of the new applicators, a cooling merit parameter was defined, which was able to compare the cooling capacity in both series of applicators. The use of simulation technologies has proven to be a useful tool for designing new cryoadipolysis devices, as it provides the opportunity to simulate biological procedures with virtual models.^[4,5,6]

The primary objective of this study is to evaluate the ultimate results of the new 360° applicators compared to the previous generation of Cooltech applicators.

The secondary objective of this study is to evaluate the efficacy of Cooltech Define for providing up to 4 simultaneous treatments.

Methods

Study design and population

Two studies were conducted at Cocoon Medical Laboratories in Barcelona (Spain), which were performed with both the new generation (Cooltech Define, hereinafter referred to as "Device 1") and the currently marketed cryoadipolysis devices (Cooltech, hereinafter referred to as "Device 2"). During the procedure, Device 1 provides lower temperatures than Device 2. The applicators of Device 1 provide 360° complete cooling of the treated area, whereas the applicators of Device 2 operate via parallel cooling in the inner cavity (Fig. 1). On Device 1, the depth of the applicator cavity is also shallower compared to the applicators on Device 2 (Fig. 2). The Device 1 applicators were: (1) Curved, (2) Tight, (3) Straight, (4) Oval, (5) Oval Curved, (6) Tiny and (7) Tiny curved. (Fig. 3). The Device 2 applicators were: (1) Straight, (2) Curved, (3) Tight and (4) Tiny.

Device 1 can make use of 4 applicators to treat up to 4 areas simultaneously, while Device 2 can use 2 applicators (Fig. 4).



Figure 1. From left to right: the Cooltech applicator with cooling plates on the sides of the cavity, and the Cooltech Define applicator with a full cooling cavity.

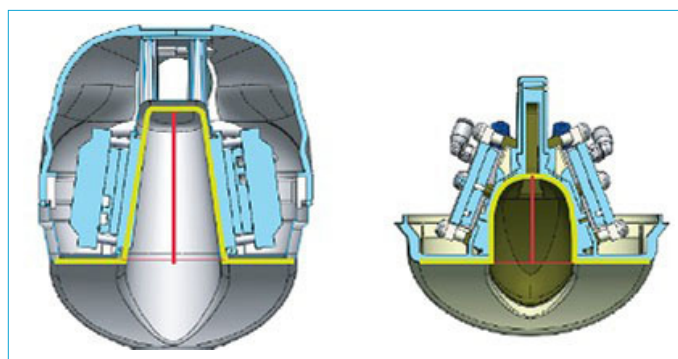

Figure 2. From left to right: Cooltech applicator and Cooltech Define applicator.



Figure 3. Cooltech Define applicators from left to right: Curved, Tight, Straight, Oval, Oval Curved, Double and Tiny.

Study 1 was a single-center retrospective study conducted from December 15th 2017 to March 15th 2018. All 10 female subjects received simultaneous procedures with Device 1 and Device 2 on symmetrical areas of various regions of the body. One to two cryoadipolysis sessions were performed.

Study 2 was a single-center prospective study conducted at Cocoon Medical in Barcelona (Spain), from June 17th 2019 to September 20th 2019. A total of 23 subjects (17 women and 6 men) were involved in the study. All subjects underwent one cryoadipolysis session using Device 1 in which they received simultaneous treatments on different areas of the body.

The procedure followed the Cooltech®.

The studies were conducted in compliance with the principles set forth in the current version of the Declaration of



Figure 4. Cooltech Define with 4 applicators.

Helsinki, Good Clinical Practice, and the laws and regulatory requirements for the use of medical devices in Spain. All subjects were well consulted, gave consent and clearly understood the procedure prior to the study. All procedures fulfilled Organic Law 15/1999 on the Protection of Personal Data and Regulation (EU) 2016/679 of the European Parliament and the Council of April 27 2016, concerning the protection of natural persons in terms of the processing of personal data and the free circulation of said data.

All subjects had discrete fat bulges in different bodily areas, a $BMI \leq 30$ and volunteered to receive the cryoadipolysis procedure for localized unwanted fat reduction. Pregnancy, breastfeeding, acute inflammation, cryoglobulinemia, Raynaud's disease or any illness listed in the contraindications and warnings were not considered in this study. Chemical exfoliation, dermabrasion, laser depilation or any other potential procedures that may increase the sensitivity of skin were also not considered in this study. Subjects stated that they did not receive any other body-remodeling procedures in the 6 months prior to this study. In order to achieve an accurate comparison, all subjects were requested to maintain

their body weight after the procedure, those subjects who gained 1 kg or more were excluded from the study. All subjects that successfully received the procedure were 18 years old or above, and both genders were involved.

Study protocol

All subjects received adequate explanations and fully understood the technology, the device, the measurement method, the procedure and the goal of this study. All subjects consented without confusion.

Study 1

All 10 subjects received two simultaneous procedures on symmetrical areas (left and right) with Device 1 and Device 2, using the same model of applicator for both devices. The sides of the body on which the subjects received Device 1 and Device 2 were randomized. 7 subjects received one session and 3 received two sessions (1 of the subjects received the sessions on the same areas and the other 2 subjects received the sessions on different areas). A total of 13 cryoadipolysis sessions were carried out, including 9 on the flanks with the Curved applicator, 1 on the infrascapular area with the Tiny applicator, 2 on the infraumbilical area with the Straight applicator, and 1 on the suprascapular area with the Tight applicator. Sessions were adapted to the profile of the subjects and the applicators available for each device.

Study 2

All 23 subjects received simultaneous procedures in different areas with Device 1, which allowed up to 4 areas to be treated at the same time. The available applicators for Study 2 were (1) Curved, (2) Oval, (3) Oval Curved, (4) Straight and (5) Tiny Curved. Table 1 shows the details of the procedures, which were adapted to the profiles of the subjects and the applicators available for Device 1.

Pre-cryoadipolysis procedure: All information was recorded individually by the researchers, including medical history, gender, age and height. Weight, fat percentage, water percentage, muscle mass, basal metabolism and BMI were recorded and calculated using bioimpedance (Tanita Model BC-730 InnerScan). The before photos of the subjects were taken using a Canon EOS 1300D camera. In order to collect a comprehensive set of clinical data, the thickness of the fat fold and the circumference of the treated area were also measured using a consistent method.

Cryoadipolysis procedure: Anesthesia was not requested for the cryoadipolysis procedures using Device 1 or Device 2, in either part 1 or 2.

Prior to the procedure, the researchers carried out a suction test to assess the suitability of the applicators and chose

Table 1. Cryoadipolysis sessions performed in Study 2

Subject	Number of areas	Treated area	Applicator
1	2	Left flank	Oval Curved
		Right flank	Oval Curved
2	2	Left outer thigh	Oval
		Right outer thigh	Oval
3	2	Left lateral abdomen	Oval Curved
		Right lateral abdomen	Oval Curved
4	4	Left flank	Oval Curved
		Right flank	Oval Curved
5	5	Right infraumbilical	Oval
		Left infraumbilical	Oval
		Left infraumbilical	Straight
		Left outer thigh	Oval Curved
		Right outer thigh	Oval
6	3	Left infrapectoral	Tiny Curved
		Right infrapectoral	Tiny Curved
		Central infraumbilical	Straight
		Left flank	Oval
7	2	Right flank	Oval
		Central infraumbilical	Curved
		Central supraumbilical	Oval Curved
8	3	Central supraumbilical	Oval Curved
		Central infraumbilical	Straight
		Left outer thigh	Oval
9	4	Right outer thigh	Oval
		Central infraumbilical	Straight
		Central supraumbilical	Oval Curved
		Left lateral abdomen	Curved
10	3	Right lateral abdomen	Curved
		Central infraumbilical	Curved
		Left outer thigh	Oval
11	3	Right outer thigh	Oval
		Central infraumbilical	Straight
		Left lateral abdomen	Oval Curved
12	3	Right lateral abdomen	Oval Curved
		Central infraumbilical	Straight
		Left flank	Oval Curved
13	3	Right flank	Oval Curved
		Central infraumbilical	Straight
		Left flank	Oval Curved
14	2	Right flank	Oval Curved
		Left abdomen	Oval
15	6	Right abdomen	Oval
		Left flank	Oval
		Right flank	Oval
		Central infraumbilical	Straight
		Right inner thigh	Oval
		Left inner thigh	Oval
16	6	Central supraumbilical	Straight
		Left inner thigh	Oval
		Right inner thigh	Oval

Table 1. Cont.

Subject	Number of areas	Treated area	Applicator
17	3	Central supraumbilical	Oval Curved
		Central infraumbilical	Straight
		Left lateral abdomen	Oval Curved
		Right lateral abdomen	Oval Curved
18	2	Central infraumbilical	Tight
		Left outer thigh	Oval
		Right outer thigh	Oval
19	4	Central infraumbilical	Tight
		Right outer thigh	Oval
		Left outer thigh	Oval
		Right outer thigh	Oval
20	1	Central infraumbilical	Straight
		Central supraumbilical	Oval Curved
		Left abdomen	Straight
21	3	Central infraumbilical	Straight
		Left outer thigh	Oval
		Right outer thigh	Oval
22	2	Left lateral abdomen	Oval
		Right lateral abdomen	Oval
23	1	Central infraumbilical	Oval Curved

the applicator that best fitted the target body area. The maximum level of suction was used for both devices.

The procedure includes five consecutive steps, 1) Cryo-protection: a cryoprotectant membrane, the Cool Gel Pad® [this product is associated with patent applications WO2018/060533 A1 and PCT ES2018/070185], is applied to the target area [7]; 2) Suction: the applicators apply a vacuum to suck up and draw in the tissue in the target area towards the crown of the applicator; 3) Cooling: consistent and controlled cooling is applied from the start of the procedure in an effort to lower the temperature of the target area; 4) Massage: a massage is performed immediately after the treatment for 2-5 minutes, and 5) Clearance: lysed adipocytes are eliminated through the lymphatic system and liver over a period of 2-3 months.

The temperature and procedure time with Device 1 was -10°C and 70 minutes, with Device 2 it was -8°C and 70 minutes. For the Tiny and Tiny Curved applicators on both Device 1 and Device 2, it was -5°C and 45 minutes.

Post-cryoadipolysis session: Subjects were asked to maintain their usual activity. No specific diet and no extra exercise should be performed after the procedure. The potential side effects were explained and the post-procedure care document was given to patients which included the contact person and number.

Participant follow-up: In Study 1, all subjects were asked to complete a questionnaire at 3 days and between 4–7, 8–15 and 16–30 days after the cryoadipolysis session. A face-to-face follow-up was conducted at the 60–90 days visit. In Study 2, face-to-face follow-ups were conducted 30–90 days after the procedure.

Data assessment:

Study 1

Temperature: The temperature on the Cool Gel Pad® membrane and on the skin in the treated area was measured immediately after the procedure with a FLUKE Ti200 infrared thermal imaging camera.

Time elapsed: (1) From the beginning of the procedure until the moment of hypoesthesia through cold, (2) from the end of the procedure until the recovery of skin sensitivity in the treated area.

Discomfort level: (1) During the suction test, (2) during the massage immediately after the procedure, (3) 30 minutes after the procedure, and at (4) 3, (5) 4–7, (6) 8–15 and (7) 16–30 days after the procedure. The intensity of discomfort was assessed using the Visual Analogue Scale (VAS), with the discomfort being classified as pain-free (VAS equal to 0), mild pain (VAS between 1 and 3), moderate pain (VAS between 4 and 7) or intense pain (VAS between 8 and 10).

Side effects: Erythema, edema, hematoma and paresthesia/dysesthesia were assessed at (1) 3, (2) 4–7, (3) 8–15 and (4) 16–30 days. They were classified in terms of severity based on a scale of 0 to 3, where 0 was the absence of side effects, 1 was mild side effects, 2 was moderate side effects and 3 was severe side effects.

Study 2

Efficacy: Weight and BMI were measured using the Tanita Model BC-730 InnerScan, the skin fold in the treated area was measured using a caliper, and the perimeter circumference at the height of the treated area was measured using a measuring tape. Iconography was recorded using a Canon EOS 1300D camera. These data were clearly recorded and the results were analyzed before the procedure and 1–3 months afterwards.

Side effects: All side effects were reported, as well as their severity and duration. Investigators took photographs in cases of possible adverse reactions or suspected incidences.

Statistical Analysis

Study 1

Descriptive statistical analysis was used for study 1. Mean value, standard deviation (SD) and range were used to eval-

uate the quantitative data (age, weight, temperature and time), while mean value and standard error (SE) were used to evaluate the categorical data (side effects). Side effects were described as percentages.

Study 2

The results in study 2 were expressed as the mean, standard deviation (SD) and range. A student's t-test was performed. A P-value < 0.05 was considered to indicate statistical significance.

Results

Study 1

A total of 10 female subjects were involved in the study, with an average age of 49 years (SD 11.35; range 29–61), and an average weight of 70 kg (SD 13.44, range 56–96 kg).

Table 1 shows all recorded parameters (temperature, time and discomfort level) during and after the treatment with Device 1 and Device 2.

Temperature immediately after the procedure: For Device 1 the temperature of the Cool Gel Pad was -11.32°C (SE 0.51; range -9.2 – 12.8), while Device 2 was -7.34°C (SE 0.69; range -5.4 – 11). The temperature of the skin for Device 1 was -11.05°C (SE 0.28; range -10 – 12.3) while for Device 2 it was -7.25°C (SE 0.43; range -4.5 – 10).

Time to reach cold hypoesthesia (minutes): The time to achieve cold hypoesthesia was 4.38 min (SE 0.56; range 2–10) for Device 1, and 6.85 min (SE 0.60; range 4–10) for Device 2. Device 1 was 36% quicker than Device 2.

Discomfort level: This evaluation was divided into different time periods, including during the suction test, immediately after the post-procedure massage, 30 minutes after the procedure and at the follow-ups after the procedure.

During the suction test, the data for both devices showed mild discomfort, although Device 1 showed a lower level of discomfort, which is due to the lower temperature and the design of the applicator compared to Device 2.

For the immediate post-procedure massage, discomfort was moderate with Device 1 while being mild for Device 2. 30 minutes after the procedure, mild discomfort was recorded for both devices.

The data for the follow-ups after 72 hours, 3–5 days and 7–15 days shows mild discomfort was recorded for Device 1, which was slightly higher than for Device 2, but it completely disappeared after 16 days (Graphic 1).

Side effects: The data obtained for erythema, edema, hematoma and sensitivity disorders (dysesthesia and paresthesia) are classified in terms of severity (mild, moderate

Table 2. Parameters recorded during and after the treatment in Study 1

Temperature immediately after the procedure (°C)	Device 1 Mean (SD; range)	Device 2 Mean (SD; range)
On the Cool Gel Pad, immediately after treatment	11.32 (SD1.25; -(9.2–12.8))	7.34 (SD1.81; -(5.4–11))
On the skin, after removing the Cool Gel Pad	11.05 (SD0.93; -(10–12.3))	7.25 (SD1.48; -(4.6–10))
Time to reach cold hypoesthesia (minutes)	4.38 (SD2.02; 2–10)	6.85 (SD2.15; 4–10)
Discomfort during the suction test during the treatment (VAS scale)	Mean (SE)	Mean (SE)
	2.62 (SE0.37; 38% of 2)	3.38 (SE0.40; 38% of 3)
Discomfort after the treatment (VAS scale)		
During the massage (immediately post-treatment)	4.85 (SE0.56)	3.62 (SE0.72)
At 30 minutes	2 (SE0.45)	2.08 (SE0.40)
At 72 hours	2.6 (SE0.69)	2.3 (SE0.76)
Between 3- and 7-days post treatment	1.9 (SE0.85)	1.3 (SE0.67)
Between 8- and 15-days post treatment	1 (SE0.80)	0.5 (SE0.50)
Between 16- and 30-days post treatment	0 (SE0.00)	0 (SE0.00)

SD: Standard deviation; SE: Standard error.

and severe) and represented in Table 3.

- Erythema: with device 1, 46% of subjects showed erythema at 72 hours after the treatment, decreasing to 23% at 4–7 days, 15% at 8–15 days, with complete disappearance at 16–30 days. With Device 2, 31% of subjects showed erythema at 72 hours after the procedure, decreasing to 15% at 4–7 days, 8% at 8–15 days, with complete disappearance at 16–30 days.
- Edema: inflammation or edema was present at 72 hours at a rate of 31% for both Device 1 and Device 2, decreasing to 23% (Device 1) and 15% (Device 2) at 4–7 days, 15% was recorded for both devices at 8–15 days, with complete disappearance at 16–30 days.
- Hematoma: 23% of subjects presented hematoma 72 hours after being treated with Device 1, compared to 38% for those treated with Device 2. This decreased to 15% at 4–7 days for both devices. This symptom disappeared with Device 1 at 8–15 days, while remaining in 8% of patients treated with Device 2. Complete disap-

pearance occurred at 16–30 days with Device 2.

- Paresthesia or dysesthesia: sensations of paresthesia and dysesthesia occurred in 62% of cases with both Device 1 and Device 2 in the 72 hours after the procedure. This decreased to 54% (Device 1) and 38% (Device 2) at 4–7 days, 38% was recorded for both devices at 8–15 days, and the data showed severity ratings of mild in 15% (Device 1) and 8% (Device 2) of cases at 16–30 days.

Study 2

A total of 23 subjects (17 female and 6 male) were included in the study, with a mean age of 38 years (SD10.41; range 25–60). A total of 69 areas were treated.

Table 4 shows the average measurements obtained before and after the treatment. The average baseline weight was 68.64 kg (SD12.75; range 47–102) and the average post-procedure weight was 67.84 (SD12.81; range 45–102), resulting in an average reduction of 0.80 kg (SD1.35; range (-5)–(+1); $p=5.99 \times 10^{-6}$).

Table 3. Reported side effects for Device 1 and Device 2 in study 1

Time after treatment	Erythema		Edema		Hematoma		Paresthesia/dysesthesia	
	Device 1 %	Device 2 %	Device 1 %	Device 2 %	Device 1 %	Device 2 %	Device 1 %	Device 2 %
At 72 hours	46	38	31	31	23	38	62	62
Mild	23.08	15.38	15.38	7.69	15.38	23.08	46.15	46.15
Moderate	15.38	15.38	15.38	23.08	7.69	15.38	7.69	15.38
Severe	7.69	7.69	0.00	0.00	0.00	0.00	7.69	0.00
At 4–7 days	23	15	23	15	15	15	54	38
Mild	7.69	0.00	15.38	15.38	15.38	15.38	38.46	23.08
Moderate	7.69	7.69	7.69	0.00	0.00	0.00	15.38	15.38
Severe	7.69	7.69	0.00	0.00	0.00	0.00	0.00	0.00
At 8–15 days	15	8	15	15	0	8	38	38
Mild	7.69	0.00	15.38	15.38	0.00	7.69	38.46	30.77
Moderate	7.69	7.69	0.00	0.00	0.00	0.00	0.00	7.69
Severe	0.00	0.00	0.00	0.00	0.00	0.00	0.00	0.00
At 16–30 days	0	0	0	0	0	0	15	8
Mild	0.00	0.00	0.00	0.00	0.00	0.00	15.38	7.69
Moderate	0.00	0.00	0.00	0.00	0.00	0.00	0.00	0.00
Severe	0.00	0.00	0.00	0.00	0.00	0.00	0.00	0.00

Table 4. Mean value of the measurements obtained before and after treatment in study 2: weight, skin fold and perimeter circumference

Variable	Pre-procedure Mean (SD; range) n=69	Post-procedure Mean (SD; range) n=69	Difference Mean (SD; range) n=69	p
Weight (kg)	68.64 (12.75; 47–102)	67.84 (12.81; 45–102)	-0.80 (1.35; (-5)–0.80)	5.99E-06
Skin fold (mm)	41.97 (8.89; 16–55)	34.17 (8.60; 12–55)	-7.80 (3.46; (-20)–(0))	1.62E-28
Perimeter circumference (mm)	935.9 (124.9; 550–1180)	903.6 (123.1; 550–1140)	-32.3 (18.6; (-80)–(0))	2.20E-22

The average skin fold reduction for the 69 areas was 7.80 mm (SD3.46; range 0–20; $p=1.62 \times 10^{-28}$). Figure 5 shows the representative case of a 59 year old subject who received 4 simultaneous applications and figure 6 shows the results after 57 days. The skin fold reduction range was between 26% and 36% with a maximum reduction of 13 mm on the lower abdomen. Figure 7 corresponds to a 32-year-old subject who had a skin fold reduction range between 30% and 50% with a maximum reduction of 20 mm on the infraumbilical abdomen. Another subject shown in figure 8 was treated with 3 applicators simultaneously on the flanks and lower abdomen. The follow-up at 85 days showed a circumference reduction of 60 mm on the flanks and a skin fold reduction of between 10 mm and 11 mm or 24% to 27%. The greatest decrease in this subject occurred on the lower abdomen with a circumference reduction of 45 mm.

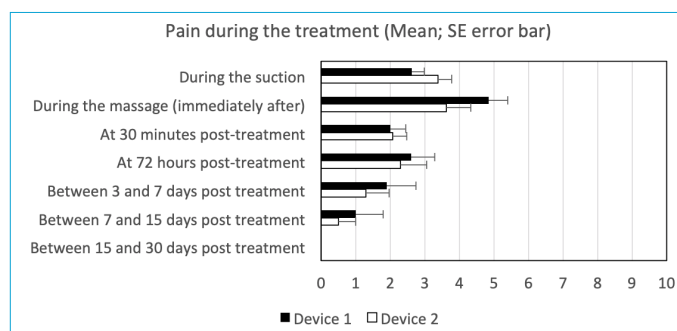
**Graphic 1.** Discomfort during and after the treatment.

In terms of circumference reduction, the average reduction for all subjects was 32.3 mm (SD1.86; range 0–8; $p=2.20 \times 10^{-22}$). The largest reduction obtained in this study was 80 mm (Fig. 9).



Figure 5. Iconography of the position using a simultaneous application of 4 applicators in the same patient: 1 Oval Curved applicator on the upper abdomen, 1 Straight applicator on the lower abdomen and an Oval Curved applicator on each of the flanks.



Figure 6. The follow-up at 57 days recorded a 50 mm circumference reduction on the lower abdomen and 45 mm on the flanks; the skin fold reductions were 13 mm (36%) on the lower abdomen, 10 mm (31%) on the left flank and 11 mm (33%) on the right flank.

Figure 10 shows the results using 2 simultaneous Oval applicators. Circumference reduction after 77 days was 40 mm and skin fold reduction was 10 mm on both thighs.

Figure 11 shows an example using 2 Tiny Curved applicators on the upper abdomen. The follow-up at 63 days presented a 30 mm circumference reduction and a 4mm skin fold reduction (25%) in both left and right sides.

The level of patient satisfaction was high with all 23 subjects, and the investigators were satisfied with the results obtained. The treatment was safe, subjects had no complaints about side effects and felt that the treatment presented no disruption to their daily schedule.

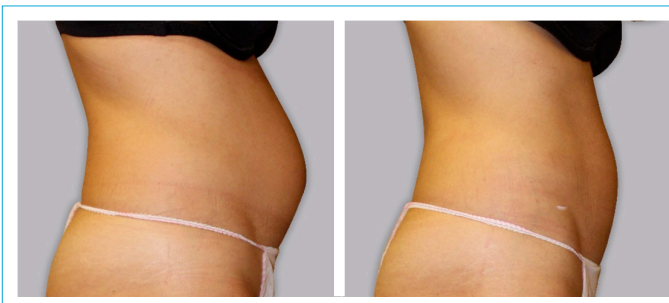

Figure 7. Iconography of the before and after results using a simultaneous application of 3 applicators: 1 Straight applicator on the central infraumbilical abdomen, 1 Oval applicator on the left outer thigh and 1 Oval applicator on the right outer thigh. Follow-up at 120 days: the circumference reduction on the central infraumbilical abdomen was 75 mm; the skin fold reduction was 20 mm or 50%. On the left and right outer thighs, the circumference measurement reduced by 70 mm and the skin fold by 15 mm or 30%.



Figure 8. Iconography of the before and after results using a simultaneous application of 3 applicators, 1 on the left flank and 1 on the right flank, and 1 Oval Curved applicator on the central lower abdomen. Follow-up at 85 days: the reduction in the circumference of the flanks was 60 mm; the skin fold reductions were 10 mm or 24% (left flank) and 11 mm or 26% (right flank). The circumference measurement of the lower abdomen was reduced by 45 mm with an 11 mm or 27% reduction of the skin fold.



Figure 9. Iconography of the before and after results of a subject that was treated on the flanks with an Oval applicator, and on the infraumbilical and supraumbilical abdomen with a Straight applicator. Follow-up at 102 days: the circumference reduction in the supraumbilical abdomen was 80 mm; the skin fold reduction was 8 mm or 22.22%. The circumference measurement of the infraumbilical abdomen was reduced by 55 mm with a 10 mm or 25% reduction of the skin fold.

Discussion

During the first minutes of the cryoadipolysis procedures when the skin reaches around 7°C, the sensation from sensory receptors begins to subside due to coldness, while



Figure 10. Iconography of the before and after results using a simultaneous application of 2 Oval applicators, 1 on the left outer thigh and 1 on the right outer thigh. The follow-up at 77 days presented a 40 mm circumference reduction; the skin fold reductions were 10 mm (left) and 10 mm (right).



Figure 11. Iconography of the before and after results using a simultaneous application of 2 Tiny Curved applicators, 1 on the left upper abdomen and 1 on the right upper abdomen. The follow-up at 63 days presented a 30 mm circumference reduction, the skin fold reductions were 4 mm or 25% (left) and 4 mm or 25% (right).

complete hypoesthesia occurs when the tissue reaches 0°C.^[8] With its lower temperature and 360° homogenous cooling plate design (Fig. 1), Cooltech Define (Device 1) decreases tissue temperature more quickly than Cooltech (Device 2), which has a parallel and less cooling capacity. Moreover, due to the shallower cavity (Fig. 2), Cooltech Define (Device 1) pulls tissue more gently than Cooltech (Device 2). Therefore, the level of total patient comfort is found to be higher with Cooltech Define (Device 1).

It is known that cryoadipolysis causes thermal damage to adipocytes and the intensity of discomfort after treatment can be directly associated with this. Due to its more intense cooling capacity, the discomfort level with Cooltech Define (Device 1) is slightly higher than with Cooltech (Device 2) from immediately after the procedure to 15 days after. The same results were noticed for side effects, especially the evaluation of erythema and paresthesia or dysesthesia. These results point to greater thermal damage being produced by Cooltech Define. All side effects were self-limiting and resolved completely after 1 month without any long-term sequelae. Notably, all subjects were able to return to daily activity without complaint.

For people of both genders across a broad age range, Cooltech Define shows significant efficacy on all areas with different applicators. The skin fold displayed an average

reduction of 7.80 mm (SD3.46) in 69 treated areas, with a p-value of 1.62×10^{-28} . The skin fold reduction percentage was between 0% and 50%. A similar study with Cooltech (Device 2) was found to produce a skin fold reduction of 19.6%.^[9] It is worth noting that the measurement of the cutaneous fold using a caliper may be affected by the force applied by each evaluator.

The outstanding efficacy provided by Cooltech Define (Device 1) with regard to the circumference measurement, with an average reduction of 32.3 mm, went as far as a notable maximum reduction of 6 cm. While previous studies with Cooltech (Device 2) showed an average reduction of 23.3 mm^[9] and 29.8 mm^[10] in the lower abdomen.

Of note that consistent results were obtained for both genders, across a broad age range and multiple body areas. This may be due to Cooltech Define (Device 1) delivering lower temperatures as well as faster and more homogenous cooling. It reaches the crystallization phase much quicker and allows the adipocyte-lysis phase to work for longer. This may contribute to the greater efficacy of the treatment, but more studies are required for definitive proof. The small sample size (Table 1) may also account for the statistics generated, therefore a larger sample size would be preferred.

Safe and tolerable results were obtained independently using 2, 3 or 4 simultaneous applicators. However, further studies should be conducted to evaluate whether multiple simultaneous cryoadipolysis treatments can increase the risk of abnormal blood triglyceride levels, lipids and liver-related tests.

These clinical results synchronize well with the previous theoretical results obtained through simulation.^[6] The simulation predicted that the new Cooltech Define (Device 1) would deliver great fat reduction results thanks to its lower temperature and faster cooling speed which provide greater patient comfort during treatment due to faster hypoesthesia.

Conclusion

Both the Cooltech and Cooltech Define procedures based on cryoadipolysis technology provide safe and highly tolerated treatments for the reduction of localized fat, with minimal and reversible side effects.

The new Cooltech Define device, which features 4 applicators for multiple treatments, provides safe and consistent clinical results. It uses a lower temperature with a new 360° applicator design that provides faster and homogenous cooling. Greater results are achieved for localized fat reduction while simultaneously providing greater patient comfort. The results show an average skin fold reduction of

7.80 mm (± 3.46 mm) with the highest reduction achieved in this study being 20 mm (a 50% reduction), and an average circumference reduction of 32.3 mm (± 18.6 mm) with the highest reduction being 80 mm.

With the results obtained it is possible to show that the prior simulations of the new applicators are reproduced when real procedures are performed. Cooltech Define provides a faster cooling speed, more homogeneous cooling, a lower cooling temperature, and therefore a faster hypoesthesia during treatment and presumably a higher percentage of damaged fat. Moreover, the newly designed devices were as safe as Cooltech, which is already commercially available. However, more clinical studies with more participants will be required to validate its safety and efficacy.

Disclosures

Acknowledgment: We would like to acknowledge to all of our co-workers from the engineering department and to the team of medical writers from i2e3 Biomedical Research Institute. A special mention to Fabiola Leon and Cristina Giménez for their valuable contribution to this research.

Ethics Committee Approval: The study was approved by the Local Ethics Committee.

Peer-review: Externally peer-reviewed.

Conflict of Interest: The authors of this publication conduct research in Cocoon Medical, which is developing products related to the research being reported. However, this review was written in accordance with objectivity in research.

Authorship Contributions: Concept – G.V.M, M.L.P.; Design – G.V.M.; Supervision – G.V.M.; Materials – C.C.O, M.L.P, G.V.M.; Data collection &/or processing – C.C.O, M.L.P, G.V.M, N.A.G.; Analysis and/or interpretation – G.V.M., M.L.P., N.A.G.; Literature search – G.V.M, M.L.P, N.A.G.; Writing – G.V.M, M.L.P, N.A.G, R.V.L, J.V.G, M.A.R.; Critical review – G.V.M, M.L.P, N.A.G, R.V.L, J.V.G, M.A.R, C.C.O., J.L.

References

1. Krueger N, Mai S V, Luebberding S, Sadick N. Cryolipolysis for noninvasive body contouring: clinical efficacy and patient satisfaction. *Clin Cosmet Investig Dermatol*. 2014;7:201.
2. Manstein D, Laubach H, Watanabe K, Farinelli W, Zurakowski D, Anderson RR. Selective cryolysis: A novel method of non-invasive fat removal. *Lasers Surg Med*. 2008;40(9):595–604.
3. Avram MM, Harry RS. Cryolipolysis for subcutaneous fat layer reduction. *Lasers in Surgery and Medicine*. 2009;41:703-708.
4. Viera-Mármol G, Villena J, García P, Khrystova K, Colina M. A Comparative Study of Cooltech® Applicators for Cryoadipolysis Using Numerical Simulation. *Probl Cryobiol Cryomedicine*. 2018;28(4):343–56.
5. Viera-Mármol G, García P, Villena J. Validation of Cooling and Freezing Dynamics of Cooltech® Using an Experimentally Adjusted Physical Model. *SAS J Med*. 2017.
6. Viera Mármol G, Villena García J. New Cooltech Define® Cryoadipolysis: A Scientific and Comparative Study with Cooltech®. *EJMI*. 2019; 3(2): 85-94.
7. Wowk B. How Cryoprotectants Work. *Cryonics/Third Quarter*. 2007.
8. Manstein D, Laubach H, Watanabe K, Farinelli W, Zurakowski D, Anderson RR. Selective cryolysis: A novel method of noninvasive fat removal. *Lasers Surg Med* 2008;40:595–604.
9. Vélez González M, Castro D, Fajardo Urdiales C, Pérez M, Viera Mármol G. Study on the Reduction of the Localized Panniculus Adiposus (Adipocyte Lysis) Through the Use of a Controlled Cooling System. *IRJPMS*, 2018;1(1).
10. Fajardo Urdiales C, Ceres Ruiz L, Mellado Soria JM, Castro D, Vélez M, Pérez MLI, Viera Mármol G, Oliva Morell J. Reducción del panículo adiposo localizado mediante un sistema de enfriamiento controlado: estudio clínico, ecográfico e histológico. *SEME*, 2019;59:20-27.